

INFORME Nº/TEST REPORT No.

19-001234742-10652

Pág. 1 de 2

Reglamento CEPE / Regulation ECE: 14.09 Supplement 0

ACERCA DE / REGARDING TO: LOS ANCLAJES DE LOS CINTURONES DE SEGURIDAD DE  
LOS VEHÍCULOS A MOTOR / SAFETY-BELT ANCHORAGES  
FOR MOTOR-VEHICLE SAFETY BELTS**I. SOLICITANTE Y VEHICULO / APPLICANT AND VEHICLE**

I.1 SOLICITANTE / APPLICANT : TRIBUS B.V.  
I.2 ASIENTO / SEAT  
MARCA / TRADE NAME : TRIBUS  
TIPO / TYPE : V-0000553\*\*\*  
DENOMINACIÓN COMERCIAL / COMMERCIAL NAME: TriflexAIR  
NOMBRE Y DIRECCIÓN DEL FABRICANTE /  
MANUFACTURER'S NAME AND ADDRESS: TRIBUS B.V.  
Proostwetering, 71  
3543 AC Utrecht (THE NETHERLANDS)

MOTIVO DE LA EXTENSIÓN / REASON FOR EXTENSION:

**II. CONCLUSIONES DEL INFORME / REPORT CONCLUSIONS**

El asiento objeto de este informe CUMPLE las prescripciones del citado Reglamento CEPE, en relación a la localización de sus anclajes efectivos / This seat FULFILLS the requirements mentioned in the above described Regulation ECE, regarding the location of effective belt anchorages.

Informe realizado por **Julio Rodrigo Ruiz**

El Jefe del Laboratorio



Miguel Manzanares

El Jefe del Área



Juan Manuel Segura

INTA, Torrejón de Ardoz, 25-10-2019

### III. RESULTADO DE LOS ENSAYOS / TEST RESULTS

#### III.1. Requerimientos relativos a la localización de los anclajes efectivos de los cinturones de seguridad / Requirements regarding the location of effective belt anchorages

PRESCRIPCIÓN/PRESCRIPTION	RESULTADO/ RESULT
Prescripciones en cuanto a número anclajes y características de los mismos / <i>Prescriptions as regards the anchorages number and its characteristics</i>	<b>CORRECTO / PASS</b>
Emplazamiento de los anclajes efectivos(*) / <i>Location of effective belt anchorages(*)</i>	<b>CORRECTO / PASS</b>

(\*) se considera que el anclaje efectivo de la hebilla coincide con su anclaje real (ver nueva configuración del anclaje de la hebilla descrita en la documentación del fabricante) / *the effective anchorage has been considered in the same position as its actual anchorage (see new buckle anchorage situation described in the manufacturer's information document).*

Lugar de ensayo / *Place of test*: **Instituto Nacional de Técnica Aeroespacial "Esteban Terradas" (INTA) - SPAIN**

Fecha de realización de los ensayos / *Date of the test*: **09-2019**



## INFORMATION DOCUMENT FOR EFFECTIVE SEAT BELT ANCHORAGE POINT TRIFLEXAIR SEAT

0. GENERAL
- 0.1. Make (trade name of manufacturer) : Tribus
- 0.2. Type : V-0000553\*\*\*
- 0.2.1. Commercial name(s) (if available) : TriflexAIR seat
- 0.3. Means of identification of type, if marked on the vehicle <sup>(b)</sup> : N/A
- 0.3.1. Location of that marking :
- 0.4. Category of vehicle <sup>(c)</sup> : M1 & M2
- 0.4.1. Classification(s) according to the dangerous goods which the vehicle is intended to transport : N/A
- 0.5. Company name and address of manufacturer : Tribus B.V.  
Proostwetering 71  
3543 AC Utrecht  
The Netherlands
- 0.8. Name(s) and address(es) of assembly plant(s) : Tribus B.V.  
Proostwetering 71  
3543 AC Utrecht  
The Netherlands
- 0.9. Name and address of the manufacturer's representative (if any) : N/A

Este documento ha sido firmado electrónicamente y su CSV es: 461a0716541221300522d2c4c7cbef5  
Para validarlo utilice la plataforma https://portal.inta.es/irj/portal/anonymous

WIJZIGINGEN		
Wijziging	Beschrijving	Datum
A	Anchorage point description modified	5-3-2019

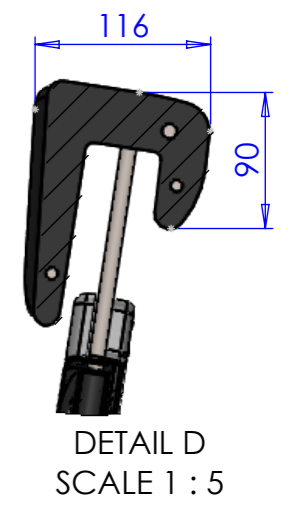
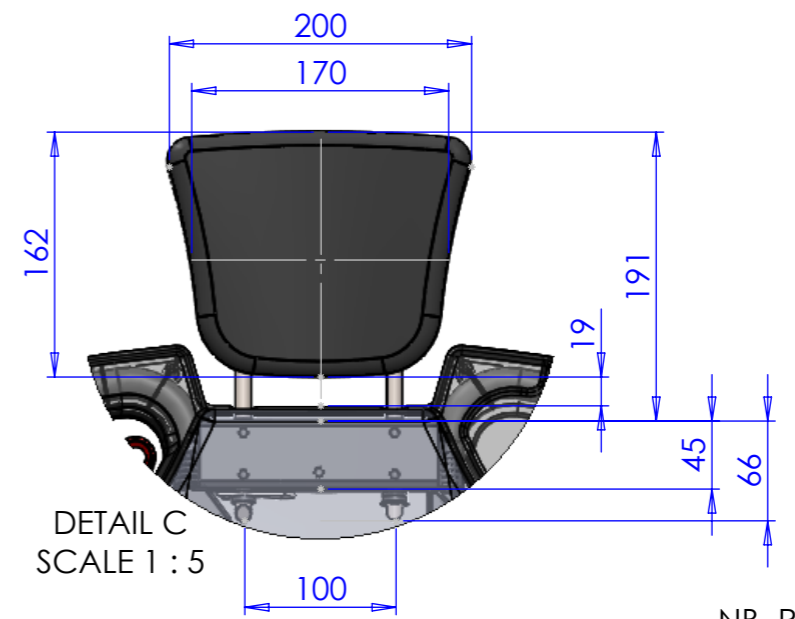
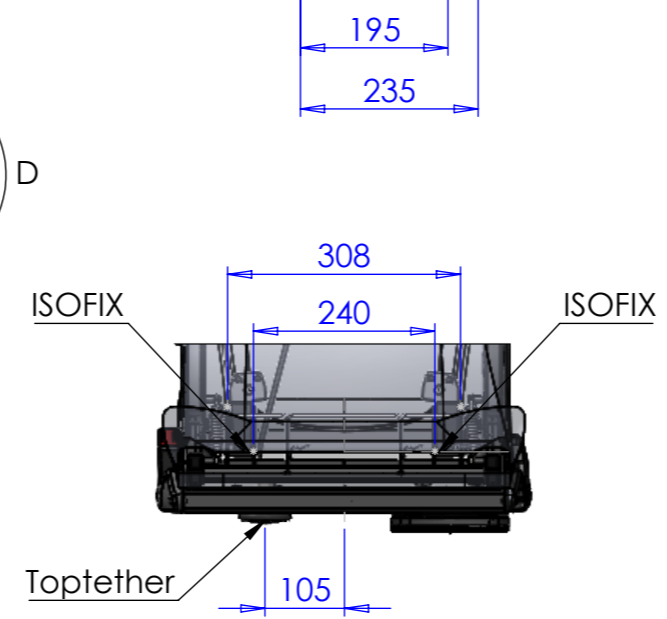
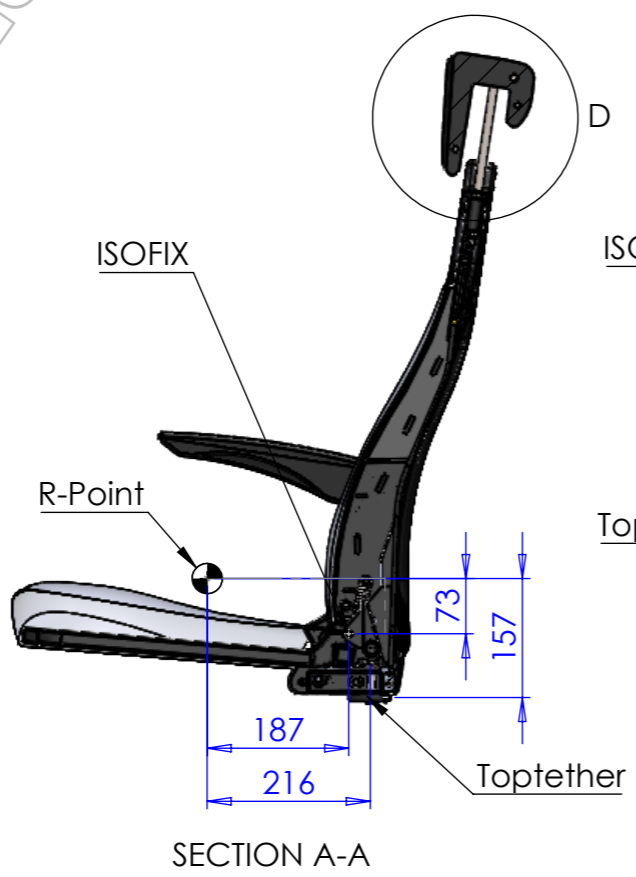
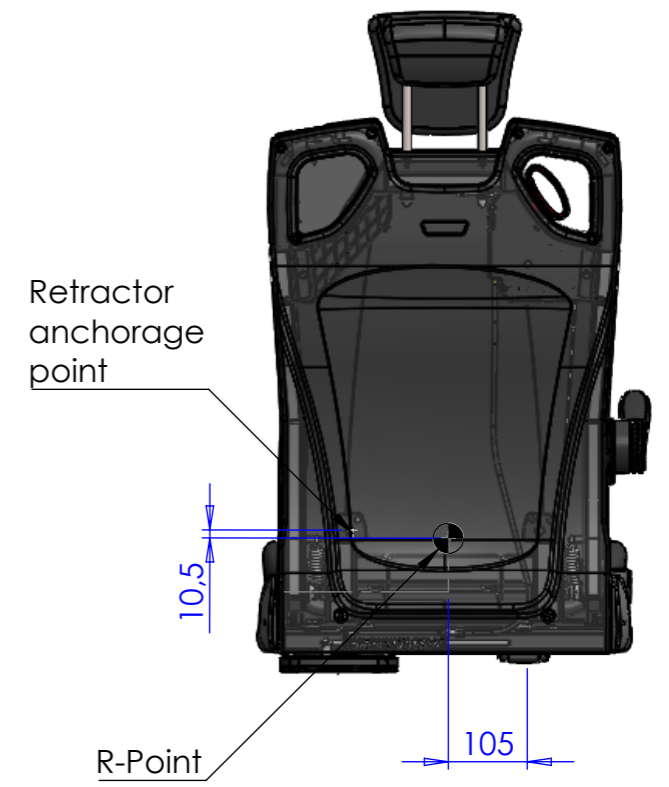
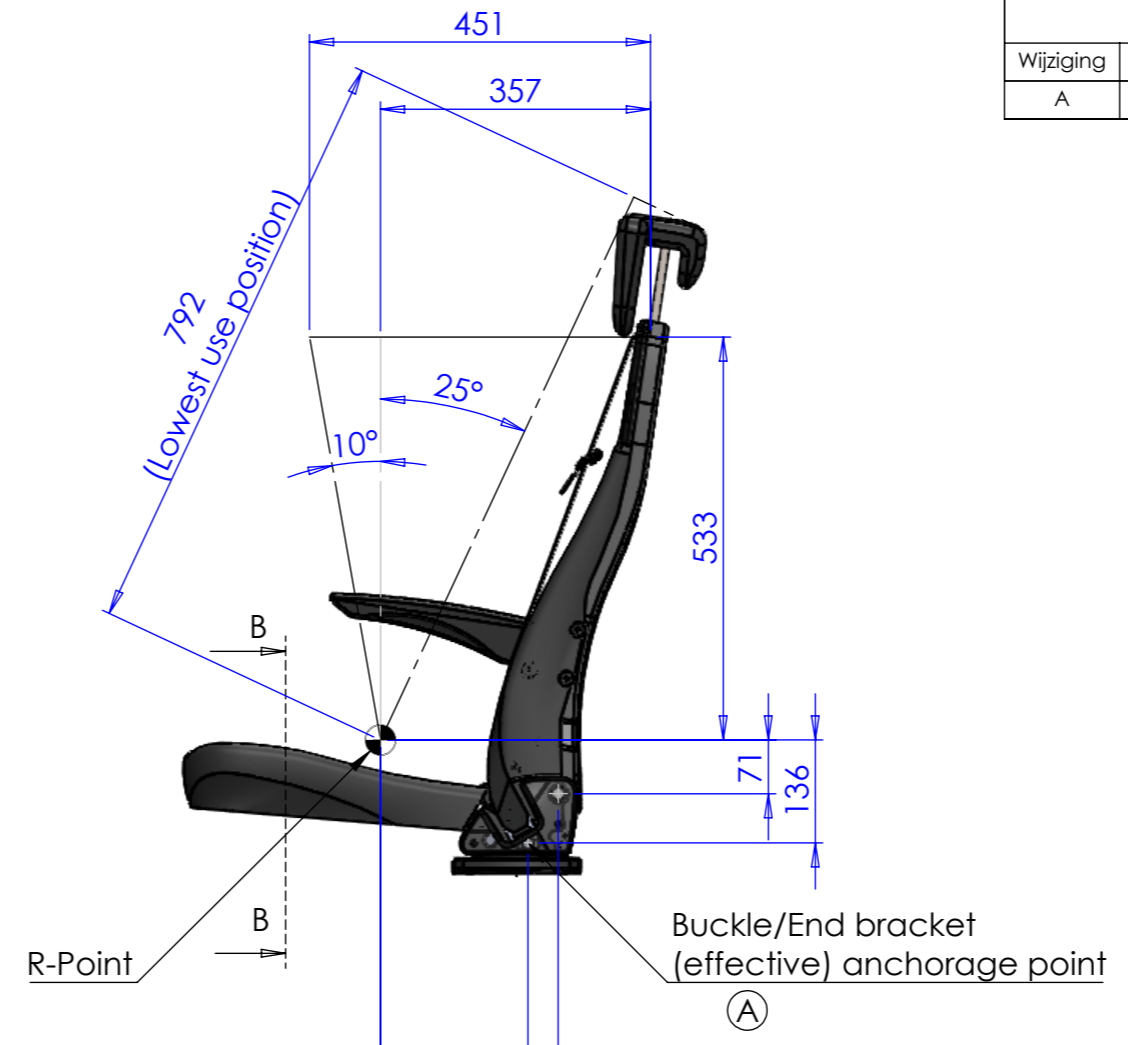

NB. PU Headrest >50 Shore A

Maattoleranties voor maten zonder tolerantieaanduiding					
Nominale maat					
Boven	-	30	400	2000	Hoeken
Tot en met	30	400	2000	4000	
Tolerantie	±0,2	±0,4	±0,8	±1,5	±0,5°

PROJ.METHODE	SCHAAL: 1:20	GETEKEND: Chun Ping Choi	Niets van deze tekening mag worden vermenigvuldigd en/of openbaar gemaakt d.m.v. druk, fotocopy, microfilm of op welke wijze ook zonder voorafgaande toestemming van TRIBUS
	MAATEENHEID: mm	GECONTR. 1: Eric van Vliet	
	DATUM: 8-3-2016	GECONTR. 2: -	
COPYRIGHT © 2016 Tribus b.v.		MATERIAAL:	OPPERVLAKTEBEHANDELING:
		BENAMING: TriflexAIR without support	
		WIJZIGING: A	FORMAAT: A3
TEK.NUMMER: V-0000553002-1			

19-00123

## TriflexAIR seat

Seatbelt buckle mounting modification



# Seatbelt buckle mounting modification

Standard situation:

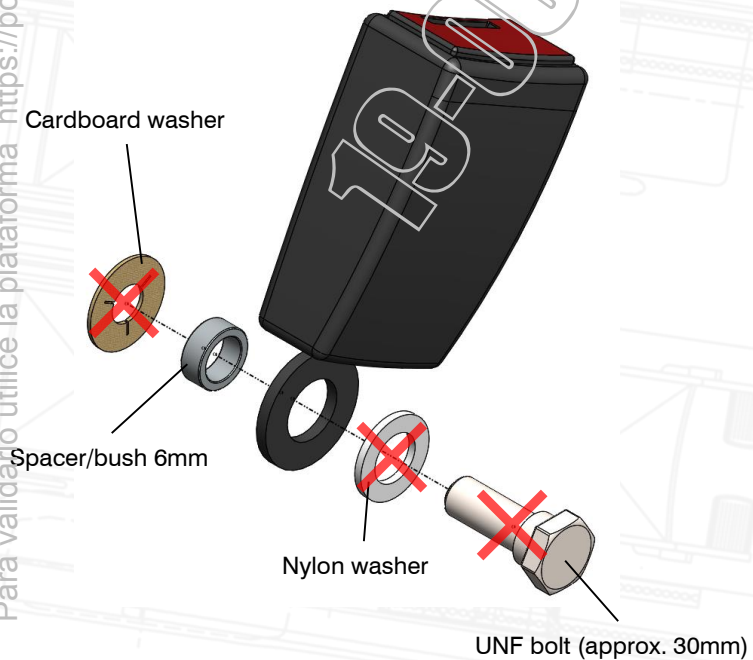

New situation:

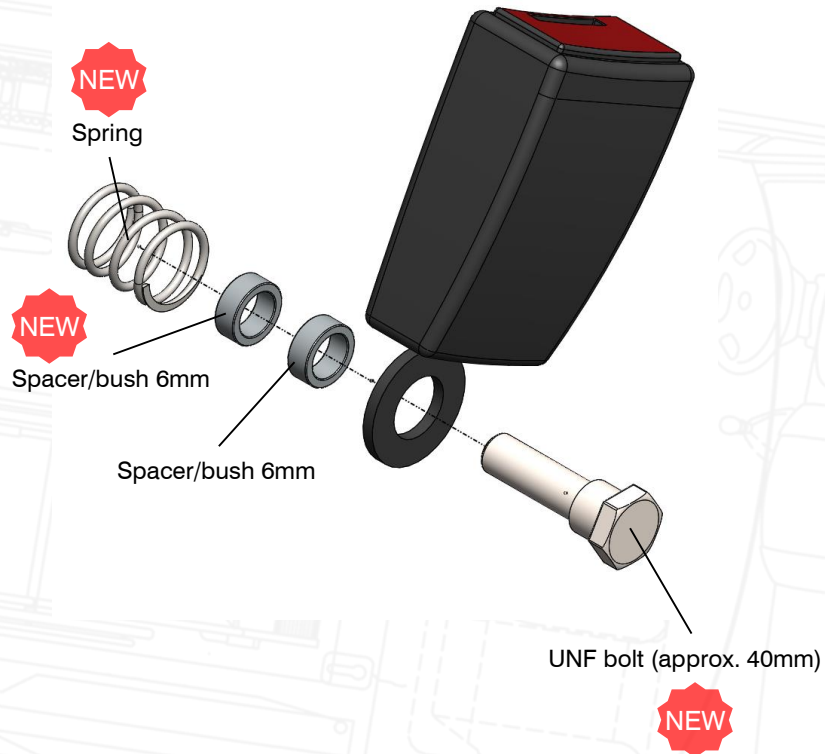

# Sidecap modification:

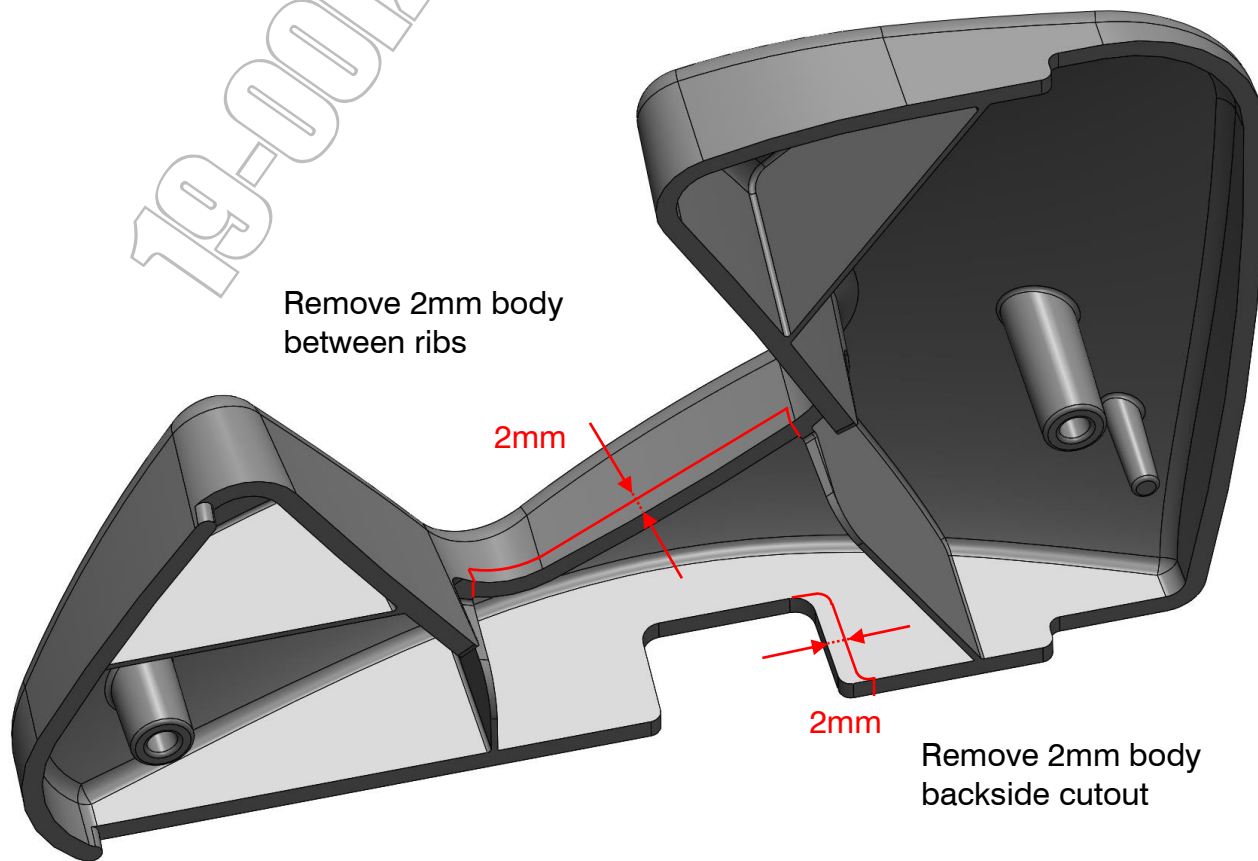

# Sidecap modification:

Este documento ha sido firmado electrónicamente y su validez legal radica en el código de documento que figura en el encabezamiento.  
Para validarlo utilice la plataforma <https://portal.inta.es/portal>

19-00125

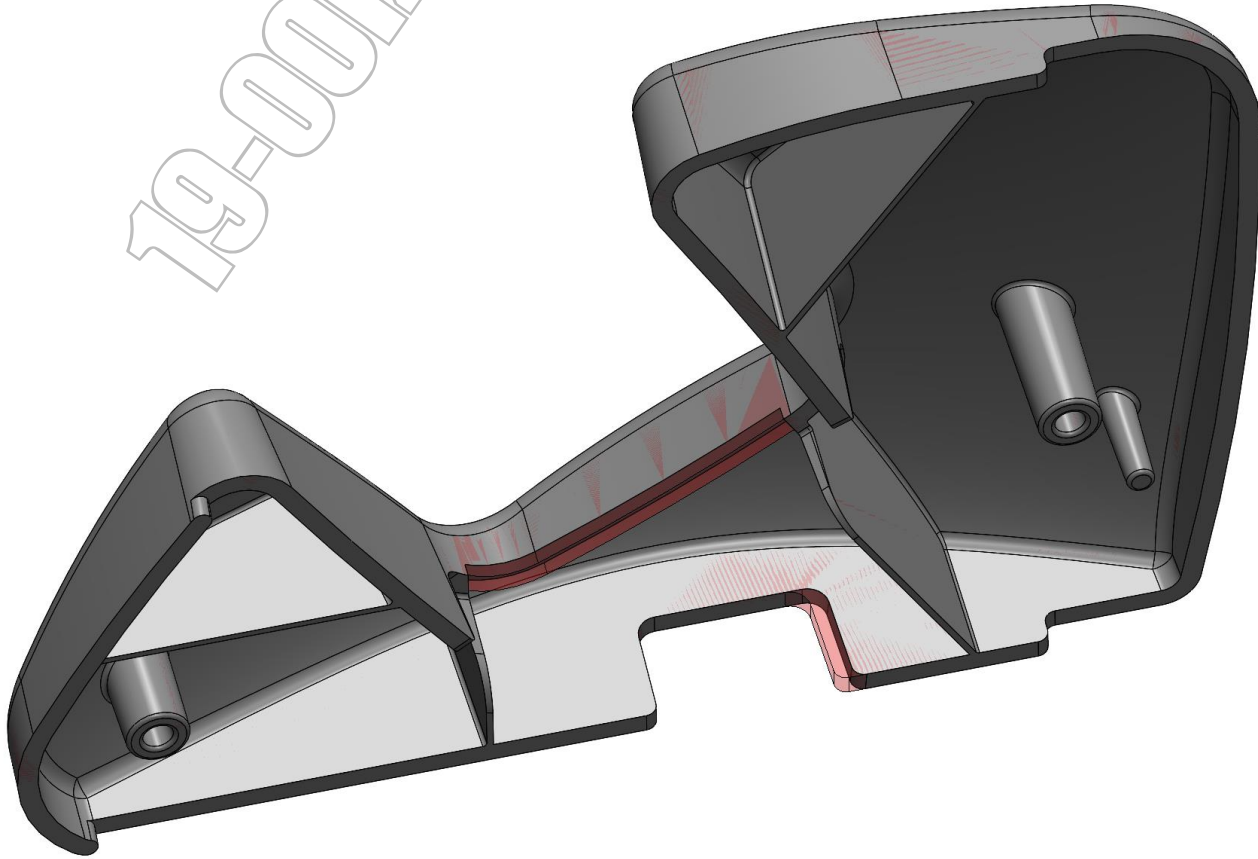



Result:

Este documento ha sido firmado electrónicamente y su validez legal se encuentra acreditada en el portal de la plataforma. Para validarlo utilice la plataforma <https://portal.inta.es/>

7° - 8°

